



TECHNICAL DATASHEET

Facade Blades

Facade Blades

Sculptform's Facade Blades system is specially designed to allow for large scale facade applications, allowing for long spans between fixings and incorporating a simple but effective connection system.

Aluminium blades up to 300mm depth can span up to 4.0m between mounting tracks, typically positioned at floor edge vicinity. The ingenious connection system makes fast installation possible, and like Click-on Battens, the designer is free to change depth along the length of a blade and space blades as required to create striking sculptured facades.

Our Facade Blade system is engineered for your peace of mind and available in a range of state-of-the-art timber-look finishes, powder-coated or anodised.

How it works

The key to the system is the mounting rail, which is fixed to the structure at the required spacing and has preset locations for the blade sequence.

Prefinished blades are then easily connected to the mounting rail. The system has been designed to maximise design flexibility while maintaining ease of installation.

Blade mounting bracket

Diecast aluminium (ADC12). Centre bolt allows blades to pivot (installation non-perpendicular to rail)

Mounting rail

Available in two sizes. 50x50mm for direct fix applications and 50x90mm for applications that require rail spanning.

Blade

Extruded aluminium

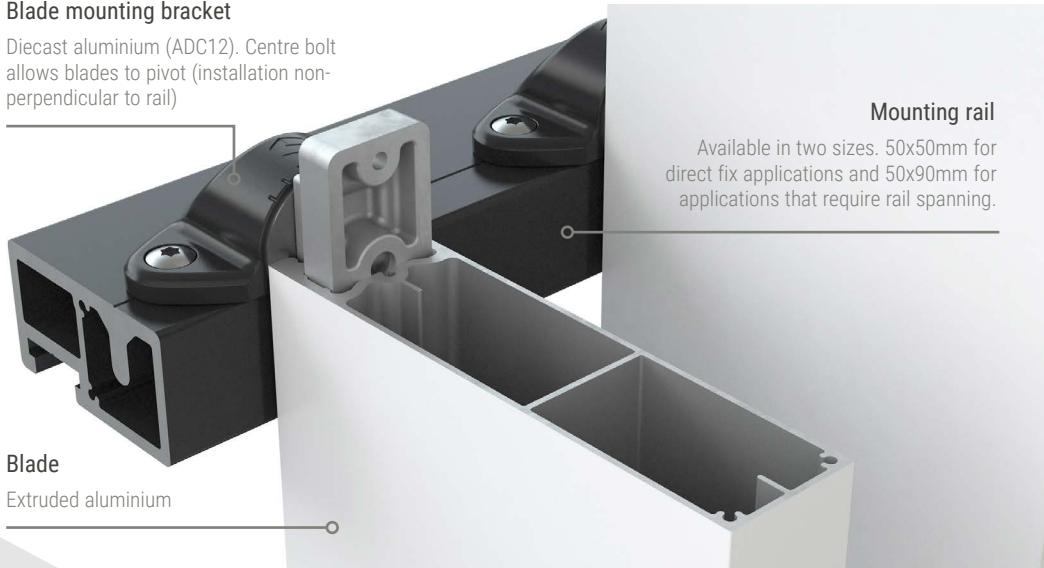

Product Specifications

Product Name	Facade Blades			
Material	Extruded Australian Aluminium			
Sizes	50x150mm	50x200mm	50x300mm	100x150mm
Alloy/Temper	6060 - T6	6060 - T6	6060 - T6	6106 - T6
Wall thickness	2.2mm ±0.25mm	2.2mm ±0.25mm	2.5mm ±0.25mm	2.0mm ±0.25mm
Approx. weight	3.756kg p/lm	4.35kg p/lm	6.023kg p/lm	4.609kg p/lm
Max. span of blades	Up to 3 metres			
Maximum Rail Curve	3 metre radius			
Maximum Cantilever	Dependant on required spans. See table on page 4 for more information.			
Aluminium Mounting Rail	50x50mm (direct fix), 50x90mm (rail spanning) Diecast Aluminium (ADC12) Can be powder coated to suit required colour for project.			
Finishes Available	Anodised, Powder coated, Timber-look Wraps. Visit sculptform.com.au for our full range.			
Combustibility	The material is NOT deemed COMBUSTIBLE according to the test criteria specified in Clause 3.4 of AS 1530.1-1994. View our certificate here .			
Warranty	10 year manufacturer's warranty. Up to 25 years available upon request. Contact us at support@sculptform.com.au for more details.			

Span Chart

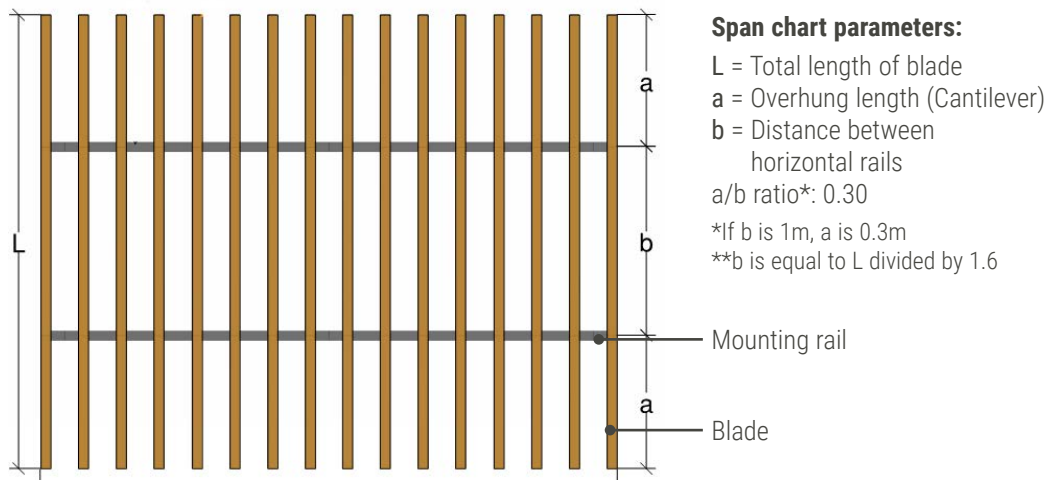

Maximum Wind Pressures (kPa)										
Blade Size (L)	Length (m)									
	2.0	2.5	3.0	3.5	4.0	4.5	5.0	5.5	6.0	6.5
50x150mm	9.5	7.6	6.3	5.4	4.7	4.2	3.8	3.4	3.1	2.9
50x200mm	8.9	7.1	5.9	5.1	4.4	3.9	3.5	3.2	2.9	2.7
50x300mm	5.5	4.4	3.7	3.1	2.7	2.4	2.2	2.0	1.8	1.7

Notes:

- This span chart is based on a simply supported beam with two equal overhangs restraint condition (as shown above).
- The span chart represents the maximum wind load in kPa that the respective blade size can withstand.
- Wind pressure tabulated above represents the wind pressure on the blade, which considers the drag coefficient of the blade and the local pressure coefficient. Note this is different to the site wind pressure.
- The span chart is calculated based on the parameters as listed above.
- The span chart above is for preliminary design only. Each project should verify the engineering for specific project purposes.
- Rail length, number and type of fixings to the base building should be checked on a project-by-project basis.
- Incidental load from building occupants/public/façade access activities have not been considered and need to be assessed project specifically.
- The blades are assessed for deflection on the following limits: span/250, and span/125. For strength, the blades are assessed on the yield strength of 6063-T6 alloy (172 MPa); and the blade to rail brackets are assessed on the yield strength of 167 Mpa.

Sculptform can assist in calculating the Maximum Wind Pressure (kPa) for your application. For assistance, email plans and any other documentation to support@sculptform.com.au.



Maintenance and Cleaning

Aluminium is a relatively low maintenance solution for any facade application. Maintenance largely depends on the degree of exposure, location of the project, and the coating used on the blades. Generally, no cleaning is required; however a typical schedule could include a visual inspection every 12 months to ensure there are no adverse environmental effects.

Surface dirt/dust, spider webs, bird droppings, rain spots and other debris, while not harmful can be unattractive and reduce the visual impact of a facade. A soft bristle broom or brush can be used to wipe the facade. Water can be used to aid the process but do not use harsh chemical cleaners as in some cases, coated layers can be removed.

Industrial and coastal environments will require a more frequent maintenance schedule to inspect for salt, visual deposits etc.

Environmental Impact

Aluminium is arguably the most sustainable building material in the world and is also highly recyclable. The recycling process creates high quality aluminium which loses none of the physical properties of primary aluminium, meaning that it can be endlessly recycled for use as new products without losing physical quality. By using aluminium products you are choosing a material whose production has minimal long term impact to the environment, is sustainable in terms of hundreds of years and endlessly recyclable.

Enquiries

More information is obtained on a project specific basis. For further information about our Facade Blades or any other Sculptform product please visit sculptform.com.au or email support@sculptform.com.au